

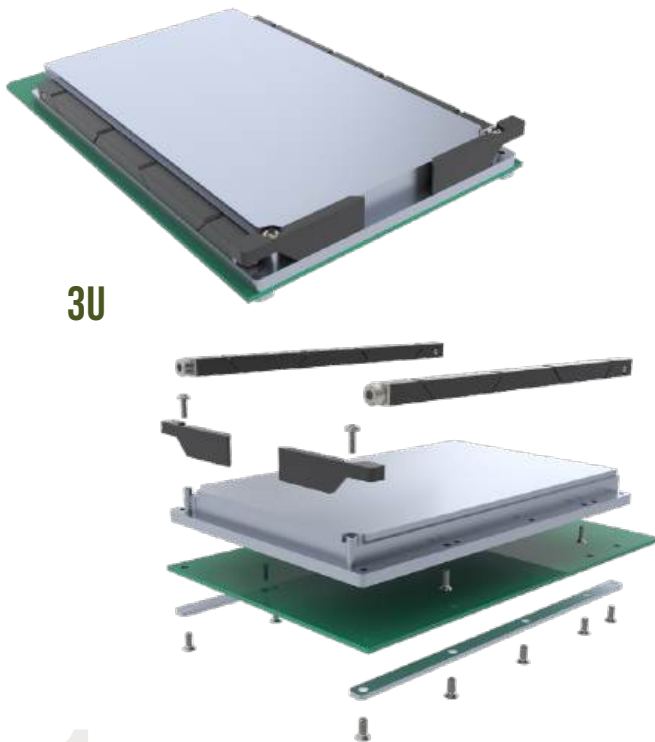

HEAT FRAME ASSEMBLY KIT DATA SHEET

C/A Design's Conduction Cooled Heat Frame Assembly Kits are manufactured from solid aluminum and allow customers to machine to the precise topography or skyline of their electronic printed circuit board while being ruggedized

When integrated with wedgelocks and ejectors, this product allows VME, cPCI and other boards to fit within conduction cooled chassis slot dimensions with zero insertion force. Heat frames can be designed for compliance with many industry standards.



3U

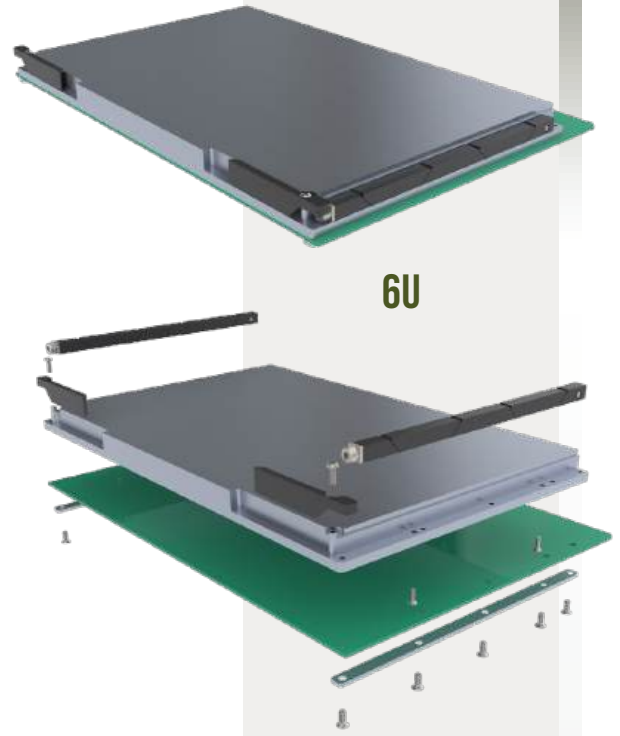

6U

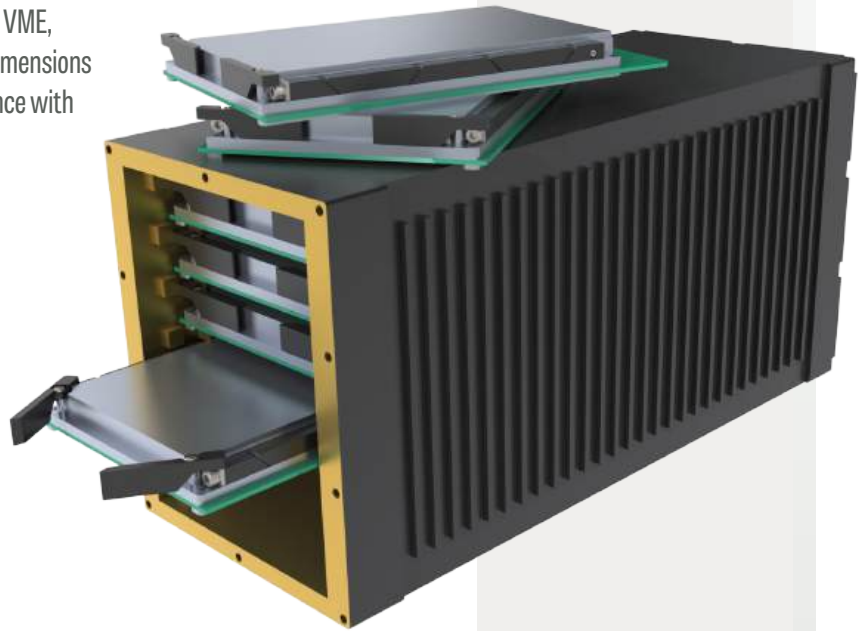

PART #	DESCRIPTION
VME-HF-3U	3U VME Heat Frame Blank Assembly Kit
VME-HF-6U	6U VME Heat Frame Blank Assembly Kit
CPCI-HF-3U	3U cPCI Heat Frame Blank Assembly Kit
CPCI-HF-6U	6U cPCI Heat Frame Blank Assembly Kit

VME-HF-3U

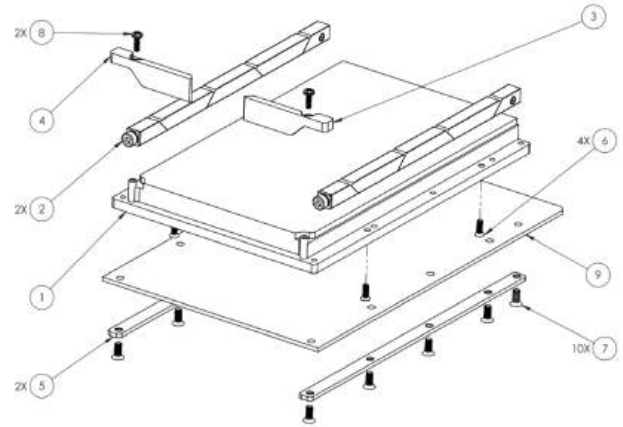
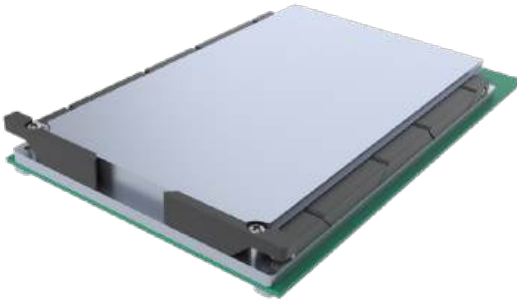

ITEM NO.	PART NUMBER	DESCRIPTION	QTY.	ITEM NO.	PART NUMBER	DESCRIPTION	QTY.
1	128791	VME HEAT FRAME 3U BLANK	1	6	NA	FH SCREW, M2 X 6MM SS	4
2	422C-480UMB	WEDGELOCK	2	7	NA	FH SCREW, M2.5 X 6MM SS	10
3	451E-150RB	EJECTOR RIGHT	1	8	NA	PH SCREW, M2 X 6MM SS	2
4	451E-150LB	EJECTOR LEFT	1	9	PCB NOT INCLUDED	PCB FOR ILLUSTRATION PURPOSES ONLY	1
5	128862	THERMAL BRACKET VME	2				

128791 VME HEAT FRAME 3U BLANK

NOTES:

- THIS IS A MACHINED PART.
- MATERIAL: AL 6061-T6.
- FINISH: BLACK ANODIZE PER MIL-A-8625, TYPE II, CLASS 2.
- ALL DIMENSIONS ARE MM.
- DIMENSIONS PROVIDED TO SUPPORT USER PCB DEFINITION. 3D MODEL AVAILABLE BY REQUEST.
- PACKAGED AS UNASSEMBLED KIT TO ALLOW FOR SECONDARY MACHINING PER CUSTOMER PCB LAYOUT.
- CONTACT US AT COMMUNICATIONS@WAKEFIELDTHERMAL.COM

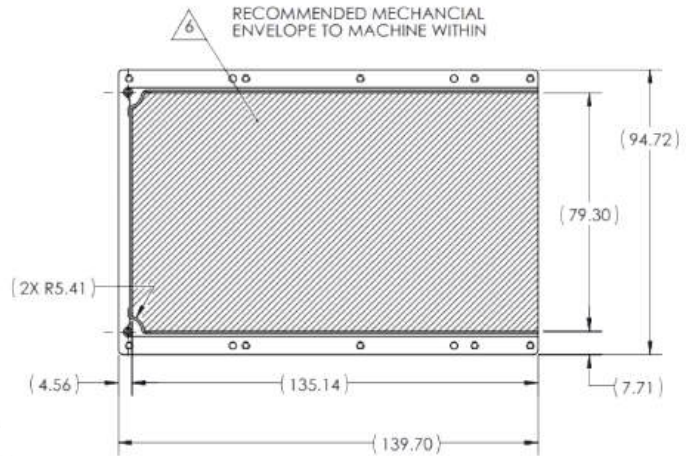
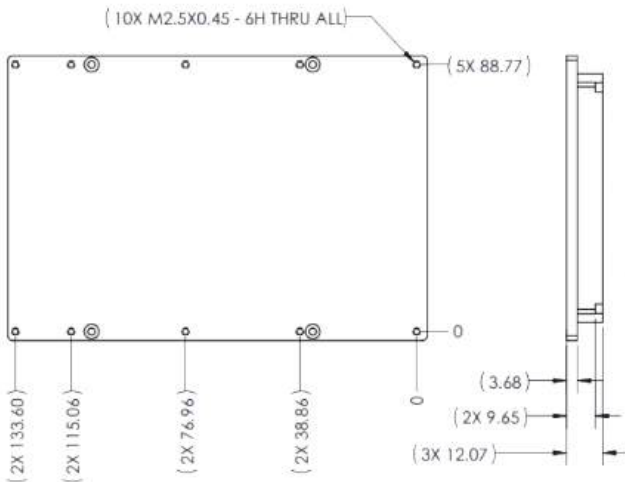

For complete heatframe assembly or other component items

CONTACT C/A DESIGN

128862 THERMAL BRACKET VME

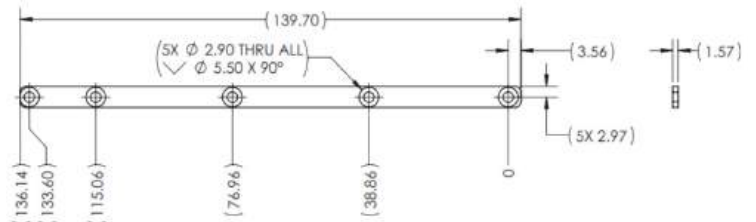

VME-HF-6U

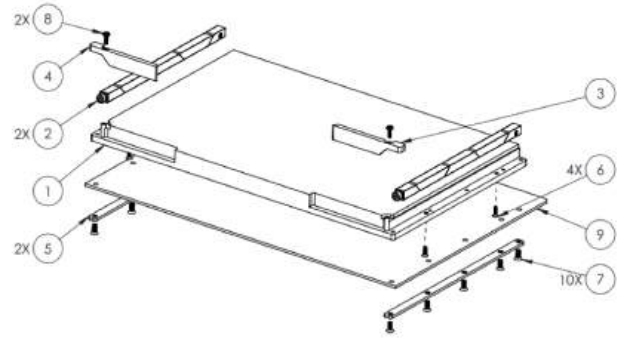
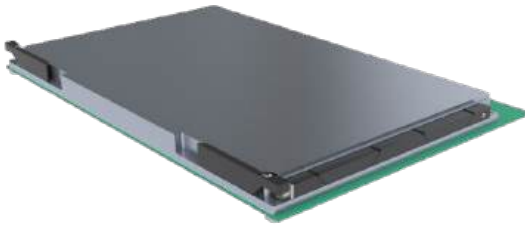

ITEM NO.	PART NUMBER	DESCRIPTION	QTY.
1	128793	VME HEAT FRAME 6U BLANK	1
2	422C-480UMB	WEDGELock	2
3	451E-200RB	EJECTOR RIGHT	1
4	451E-200LB	EJECTOR LEFT	1
5	128862	THERMAL BRACKET VME	2

ITEM NO.	PART NUMBER	DESCRIPTION	QTY.
6	NA	FH SCREW, M2 X 6MM SS	4
7	NA	FH SCREW, M2.5 X 6MM SS	10
8	NA	PH SCREW, M2 X 6MM SS	2
9	PCB NOT INCLUDED	PCB FOR ILLUSTRATION PURPOSES ONLY	1

128793 VME HEAT FRAME 6U BLANK

NOTES:

1. THIS IS A MACHINED PART.
2. MATERIAL: AL 6061-T6.
3. FINISH: BLACK ANODIZE PER MIL-A-8625, TYPE II, CLASS 2.
4. ALL DIMENSIONS ARE MM.
5. DIMENSIONS PROVIDED TO SUPPORT USER PCB DEFINITION. 3D MODEL AVAILABLE BY REQUEST.
6. PACKAGED AS UNASSEMBLED KIT TO ALLOW FOR SECONDARY MACHINING PER CUSTOMER PCB LAYOUT.
7. CONTACT US AT COMMUNICATIONS@WAKEFIELDTHERMAL.COM

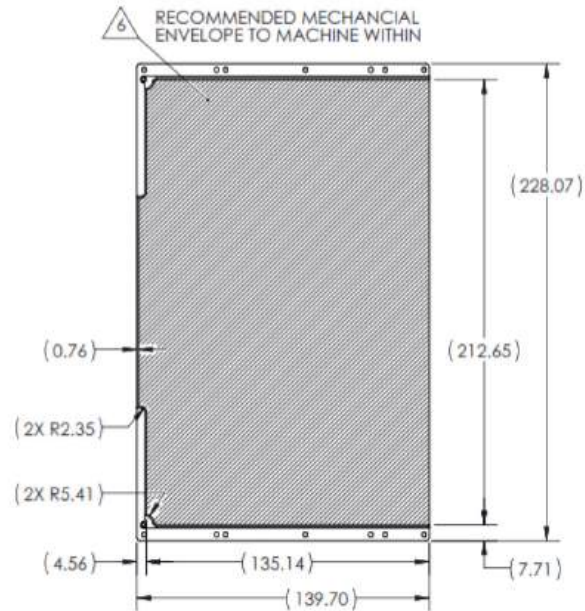
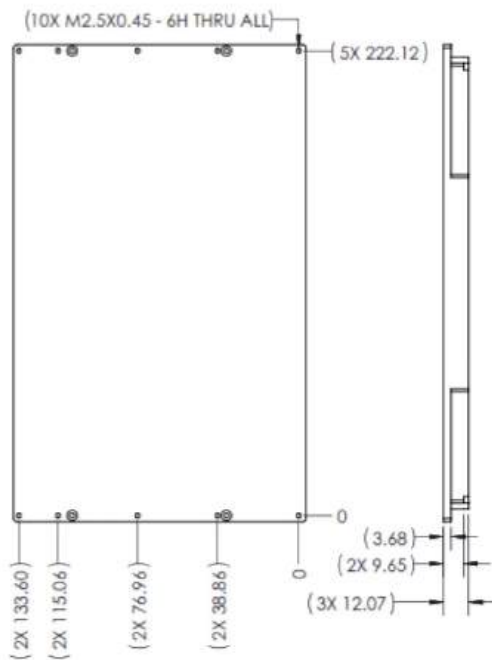

128862 THERMAL BRACKET VME

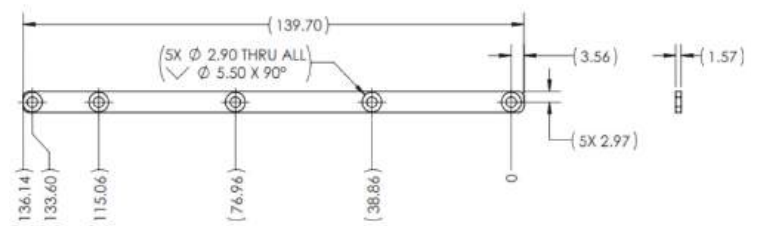

CPCI-HF-3U

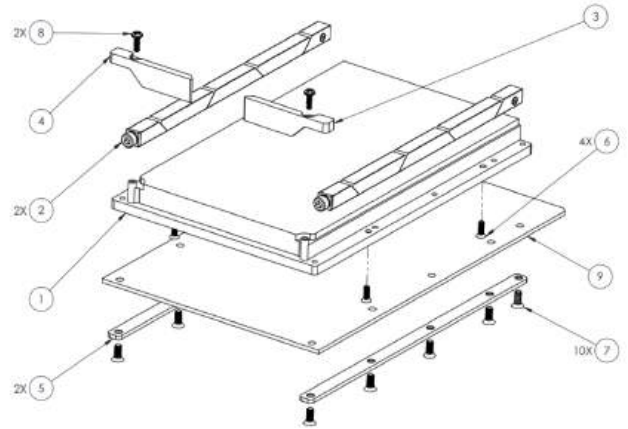
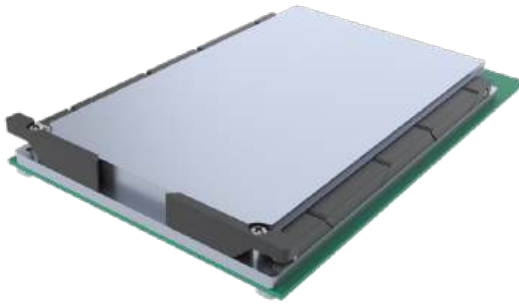

ITEM NO.	PART NUMBER	DESCRIPTION	QTY.
1	128797	cPCI HEAT FRAME 3U BLANK	1
2	422C-480UMB	WEDGELOCK	2
3	451E-150RB	EJECTOR RIGHT	1
4	451E-150LB	EJECTOR LEFT	1
5	128954	THERMAL BRACKET cPCI	2

ITEM NO.	PART NUMBER	DESCRIPTION	QTY.
6	NA	FH SCREW, M2 X 6MM SS	4
7	NA	FH SCREW, M2.5 X 6MM SS	10
8	NA	PH SCREW, M2 X 6MM SS	2
9	PCB NOT INCLUDED	PCB FOR ILLUSTRATION PURPOSES ONLY	1

128797 cPCI HEAT FRAME 3U BLANK

NOTES:

1. THIS IS A MACHINED PART.
2. MATERIAL: AL 6061-T6.
3. FINISH: BLACK ANODIZE PER MIL-A-8625, TYPE II, CLASS 2.
4. ALL DIMENSIONS ARE MM.
5. DIMENSIONS PROVIDED TO SUPPORT USER PCB DEFINITION. 3D MODEL AVAILABLE BY REQUEST.
6. PACKAGED AS UNASSEMBLED KIT TO ALLOW FOR SECONDARY MACHINING PER CUSTOMER PCB LAYOUT. CONTACT US AT COMMUNICATIONS@WAKEFIELDTHERMAL.COM
- 7.

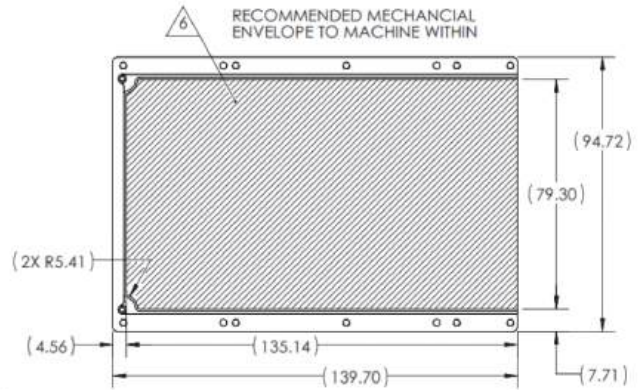
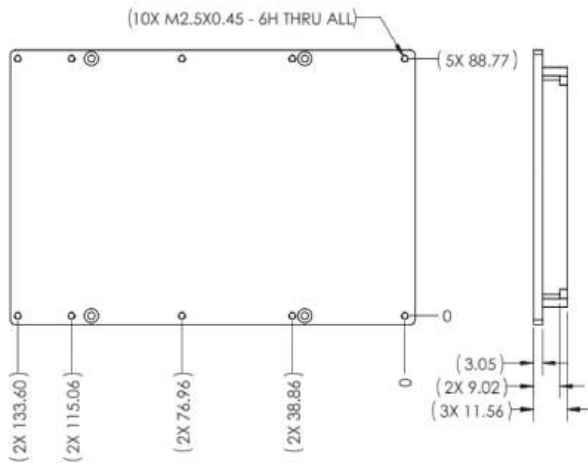

128954 THERMAL BRACKET cPCI

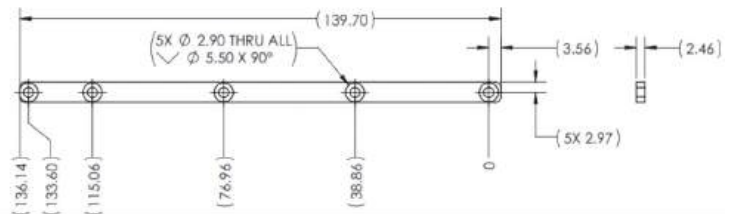

CPCI-HF-6U

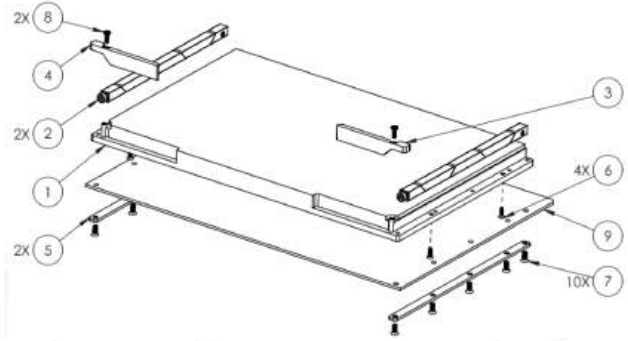

ITEM NO.	PART NUMBER	DESCRIPTION	QTY.
1	128799	cPCI HEAT FRAME 6U BLANK	1
2	422C-480UMB	WEDGELock	2
3	451E-200RB	EJECTOR RIGHT	1
4	451E-200LB	EJECTOR LEFT	1
5	128954	THERMAL BRACKET cPCI	2

ITEM NO.	PART NUMBER	DESCRIPTION	QTY.
6	NA	FH SCREW, M2 X 6MM SS	4
7	NA	FH SCREW, M2.5 X 6MM SS	10
8	NA	PH SCREW, M2 X 6MM SS	2
9	PCB NOT INCLUDED	PCB FOR ILLUSTRATION PURPOSES ONLY	1

128799 cPCI HEAT FRAME 6U BLANK

NOTES:

1. THIS IS A MACHINED PART.
2. MATERIAL: AL 6061-T6.
3. FINISH: BLACK ANODIZE PER MIL-A-8625, TYPE II, CLASS 2.
4. ALL DIMENSIONS ARE MM.
5. DIMENSIONS PROVIDED TO SUPPORT USER PCB DEFINITION. 3D MODEL AVAILABLE BY REQUEST.
6. PACKAGED AS UNASSEMBLED KIT TO ALLOW FOR SECONDARY MACHINING PER CUSTOMER PCB LAYOUT.
7. CONTACT US AT COMMUNICATIONS@WAKEFIELDTHERMAL.COM

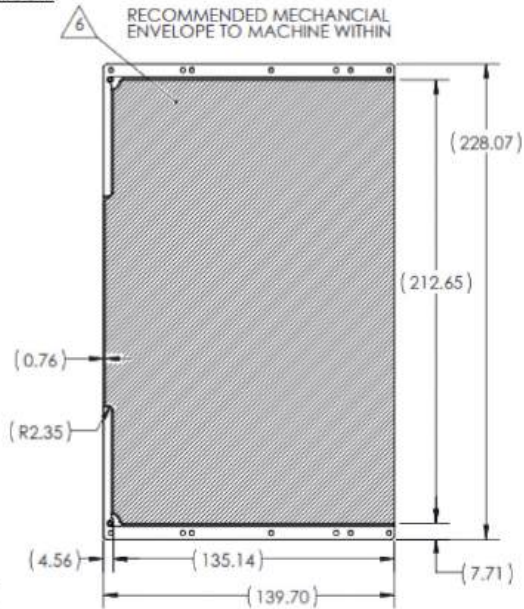
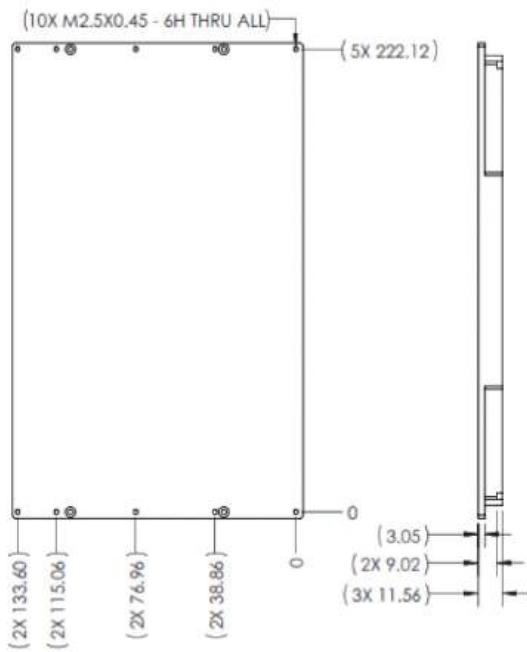

128954 THERMAL BRACKET cPCI

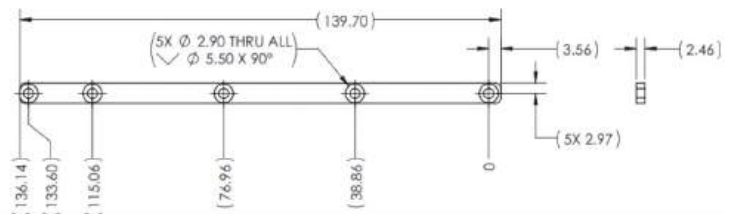



COOLVATION
Innovative Thermal Solutions

5 STEP THERMAL ENGINEERING GUIDE From Concept To Cooling

COOLVATION provides thermal management engineering services to improve products' thermal performance while applying cost effective solutions to eliminate unnecessary manufacturing costs. COOLVATION is a seamless resource extension for our customers' thermal & mechanical engineering teams from ideation to lab testing.

